

HAAS
+
SOHN

Avesta with exchanger

Equipment sheet
Fireplace stove with exchanger

GB

Introduction

We thank you very much for purchasing our product!

The description of the heating device will inform you in detail about the design, technical specification and operation of the heating device. We recommend you to acquaint yourselves closely with these data. In this way, you will avoid possible faults during the proper assembly and operation.

You will find detailed conditions of installation and operation in General Manual of Operation (included in the scope of the delivery).

Notes in the text

GB



Of utmost importance there are the notes entitled **WARNING**. The notes entitled **WARNING** advise you on **serious danger of damage to the heating device or of an injury**.



The note entitled **Notice** advises you on possible damage to your heating device.



The note entitled **Important** calls your attention to the information important for the operation of your heating device.



The note itself calls your attention to the information important for the operation of your heating device in general.

Contents

1. Technical data	1
2. Technical description	2
3. List of spare parts	3
3.1. Overall scheme of the model	3
3.2. Detail A1	5
3.3. Detail A2, A3, A4, A5.....	6
4. Dimensioned diagram	8
4.1. Knee-piece of exhaust of combustion products	8
4.2. Connection of the exchanger	9
5. Easy control	10
6. Installation of the coolant loop	11
7. Instructions for cleaning of the exchanger	12

1. Technical data



Suitable fuel:

As concerns suitable fuel to be employed, see the chapter **2.2 Fuel** in the General Manual of Operation.

Proper operation:

As concerns the proper and safe operation of the fireplace stove, see the chapters **2. Description of the combustion process** and **5. Operating instructions** in the General Manual of Operation.

Instructions for the control of combustion process

Fuel		Output of the heating device	Quantity of fuel	Primary air	Secondary air	Tertiary air
Blockwood		100%	3 kg/hour	Easy control 100%		
		33%	1 kg/hour	Easy control 50%		
Eco-briquettes		100%	2,8 kg/hour	Easy control 100%		
		33%	0,9 kg/hour	Easy control 50%		
Coal briquettes		100%	2 kg/hour	Easy control 25%		
		33%	0,7 kg/hour	Easy control 10%		

Technical data

	Blockwood	Eco-briquettes	Coal briquettes
Achieved heat output (100%)	10,1 kW	10,2 kW	10,1 kW
Nominal heat output	10 kW	10 kW	10 kW
Reduced heat output (33%)	3,3 kW	3,4 kW	3,3 kW
Output delivered by the stove body only	2,8 kW	3,1 kW	5 kW
Output available for heating of water	7,3 kW	7,1 kW	5,1 kW
Maximum stoking amount of the fuel	3 kg/hour	2,8 kg/hour	2 kg/hour
Average temperature of combustion products behind the smoke flue neck	281 °C	292 °C	232 °C
Maximum mass flow of dry combustion products	7,5 g/s	8,1 g/s	11,4 g/s
Energy efficiency	81 %	80,6 %	79,2 %
Average concentration of CO ₂	11 %	10,5 %	6,9 %
Concentration of CO in combustion products at 13% O ₂	1153 mg/Nm ³	1186 mg/Nm ³	2331 mg/Nm ³
Average concentration of dust at 13% O ₂	19 mg/Nm ³	25,5 mg/Nm ³	45 mg/Nm ³
The amount of combustion air at nominal output	22 m ³ /hour	23 m ³ /hour	30 m ³ /hour
Tested in compliance with EN 13 240			

Technical information

Height	962 mm
Width	524 mm
Depth	566 mm
Weight	185 kg
Diameter of the smoke flue	150 mm
Maximum operating over-pressure of the exchanger	0,2 MPa
Water contents of the exchanger	14 l
Recommended heat gradient (t _{output} – t _{input})	75 – 60 °C
Min. chimney stack draught in the smoke flue neck	12 Pa
Heating capacity (middle heat losses) at 10,2 kW	cca 184 m ³
Controllable output	3,3 – 10,2 kW

2. Technical description

Technical description

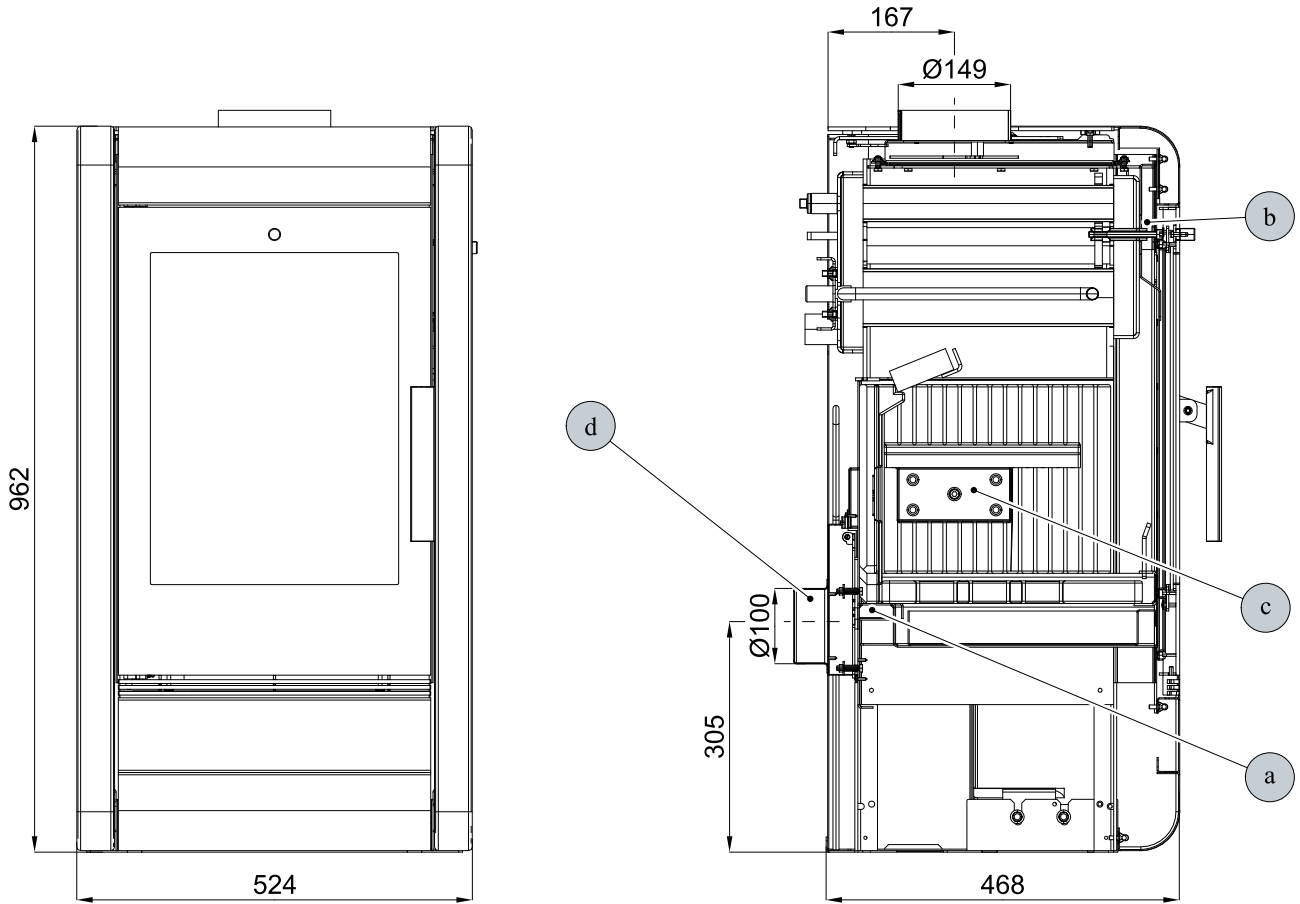

GB

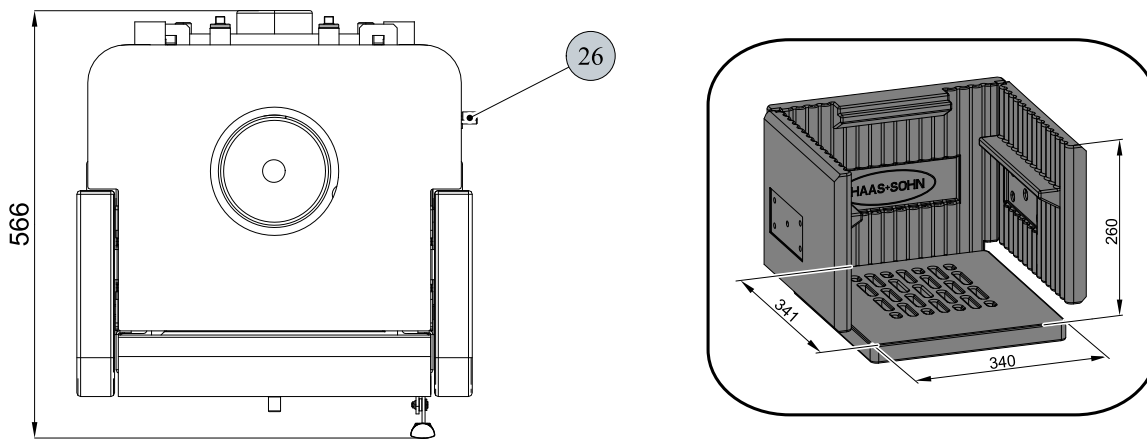

Position	Name
26	Easycontrol — Controller
a	Intake of primary air
b	Intake of secondary air
c	Tertiary air output
d	External air input (Ø100)

3. List of spare parts

3.1. Overall scheme of the model

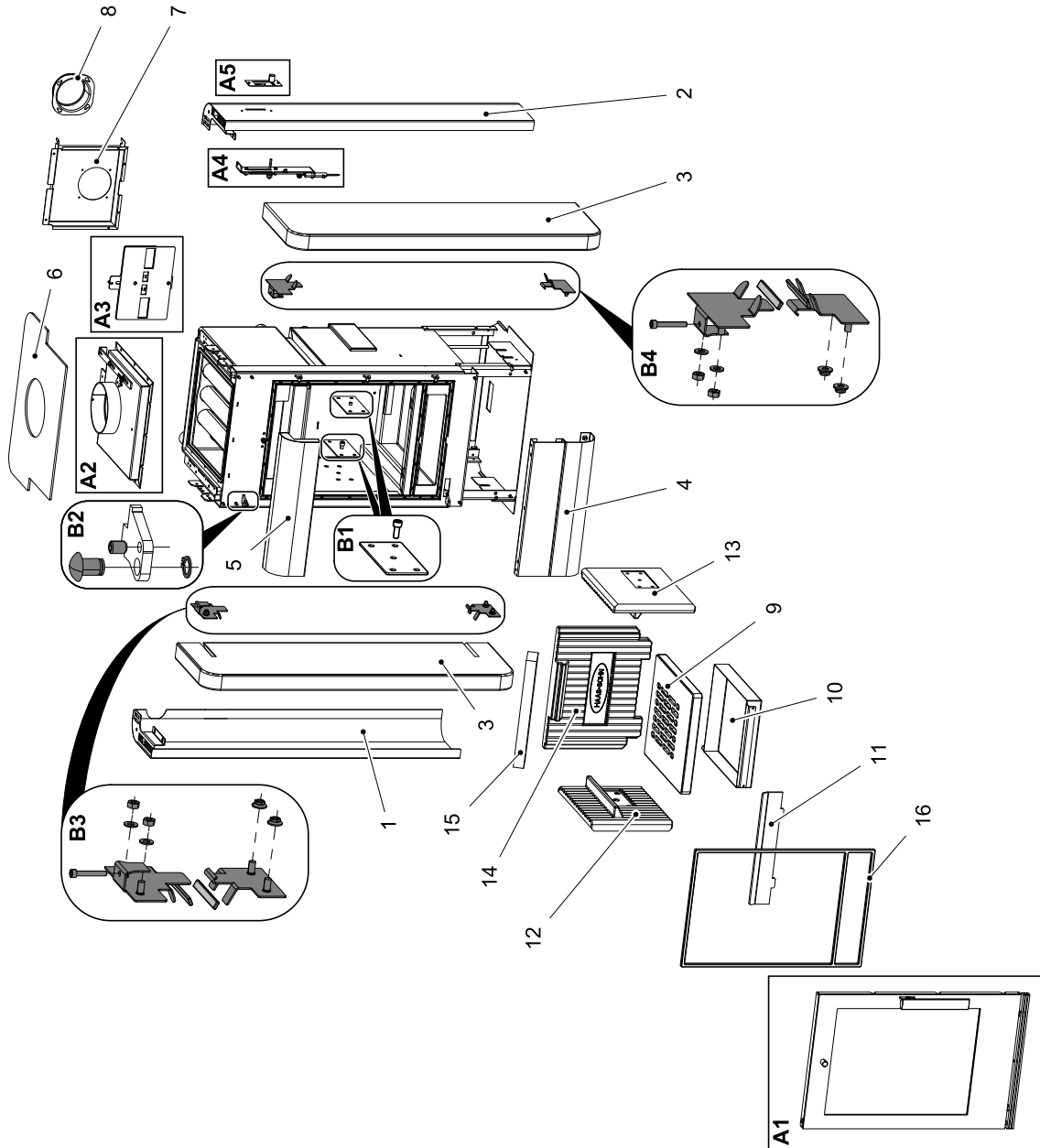

Item	Name	Quantity	Number of goods
Overall scheme of the model			
A1	Fire-box door (complete)/black-silver	1 piece	0434615005300
A2	Lid (complete)/black	1 piece	0434515015095
A3	Sliding valve (complete)/black	1 piece	0434615505004
A4	Control (complete)/Easycontrol	1 piece	0434515006060
A5	Controller (complete)	1 piece	0434615005005
B1	Lining sealing — set	1 piece	0434515005510
B2	Hinge connecting material — set	1 piece	0434515005128
B3	Holder of the lining-left/black — set	1 piece	0434615105068
B4	Holder of the lining-right/black — set	1 piece	0434615105066
1	Lateral cover — left/black	1 piece	0434515005019
2	Lateral cover — right/black	1 piece	0434515005018
3	Lateral lining/Woodstone Prestige	2 piece	0434615105050
4	Lower cover/black	1 piece	0434515015021
5	Upper cover/black	1 piece	0434515015020
6	Upper lid/black	1 piece	0434615005001
7	Rear cover	1 piece	0434515005003
8	External air input (Ø100)	1 piece	0088500050008
9	Grate/lackfire	1 piece	0434515005053
10	Ashpan	1 piece	0434515005030
11	Protection/black	1 piece	0434515005040
12	Refractory lining — left (60x250x307)	1 piece	0434615005504
13	Refractory lining — right (60x250x307)	1 piece	0434615005503
14	Refractory lining — rear (60x290x375)	1 piece	0434615005501
15	Screen — loose (30x80x330)	1 piece	0434515005555
16	Door sealing cord 12 mm	2500 mm	0040012120005

3.2. Detail A1

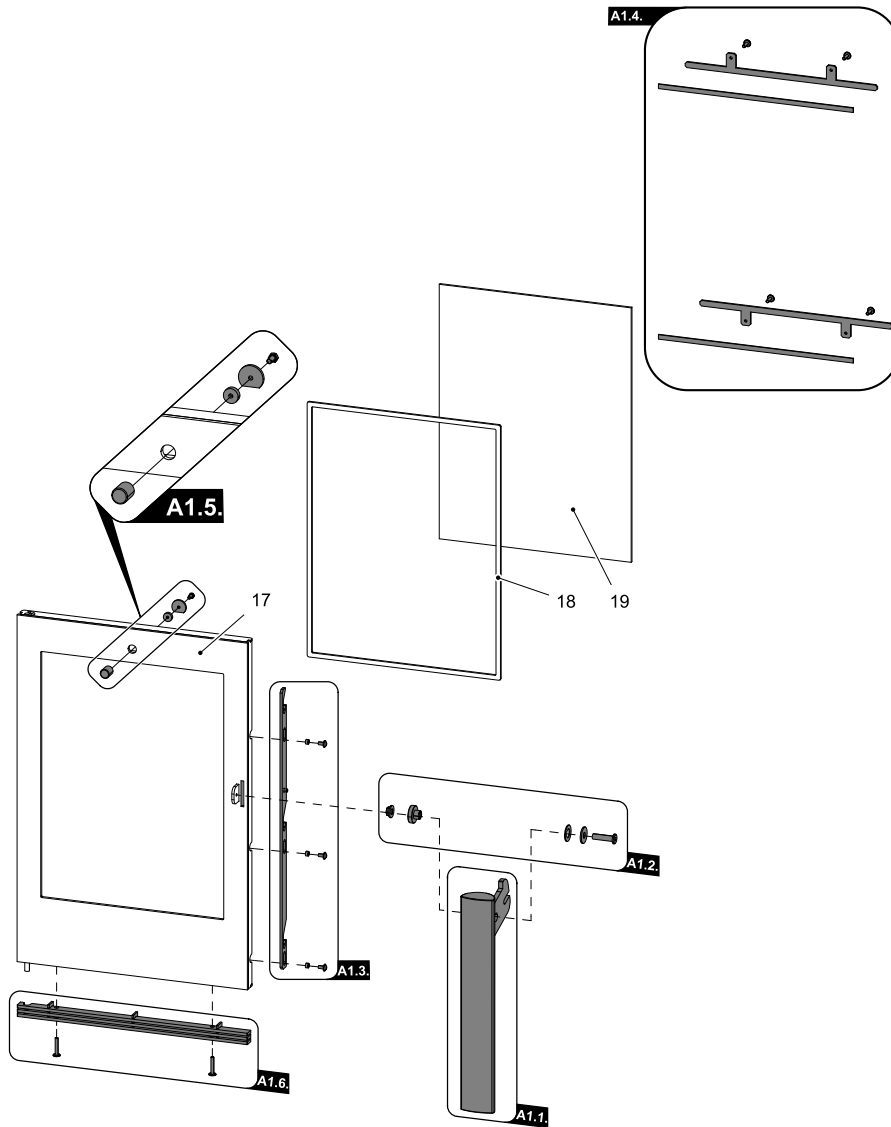

Item	Name	Quantity	Number of goods
Detail A1			
A1.1.	Fire-box door lever lock (complete)	1 piece	0429405005318
A1.2.	Handle connecting material — set	1 piece	0434615505002
A1.3.	Closing mechanism drawbar — set	1 piece	0434615005321
A1.4.	Glass holder — set/black	1 piece	0434615005330
A1.5.	Cleaning cover — set/black	1 piece	0434615505005
A1.6.	Shutter/silver — set	1 piece	0434615005315
17	Fire-box door (welded part)/black	1 piece	0434615005200
18	Glass sealing cord 10x4 mm	1660 mm	0040210040005
19	Refractory glass (380x505)	1 piece	0434515005304

3.3. Detail A2, A3, A4, A5

List of spare parts

GB

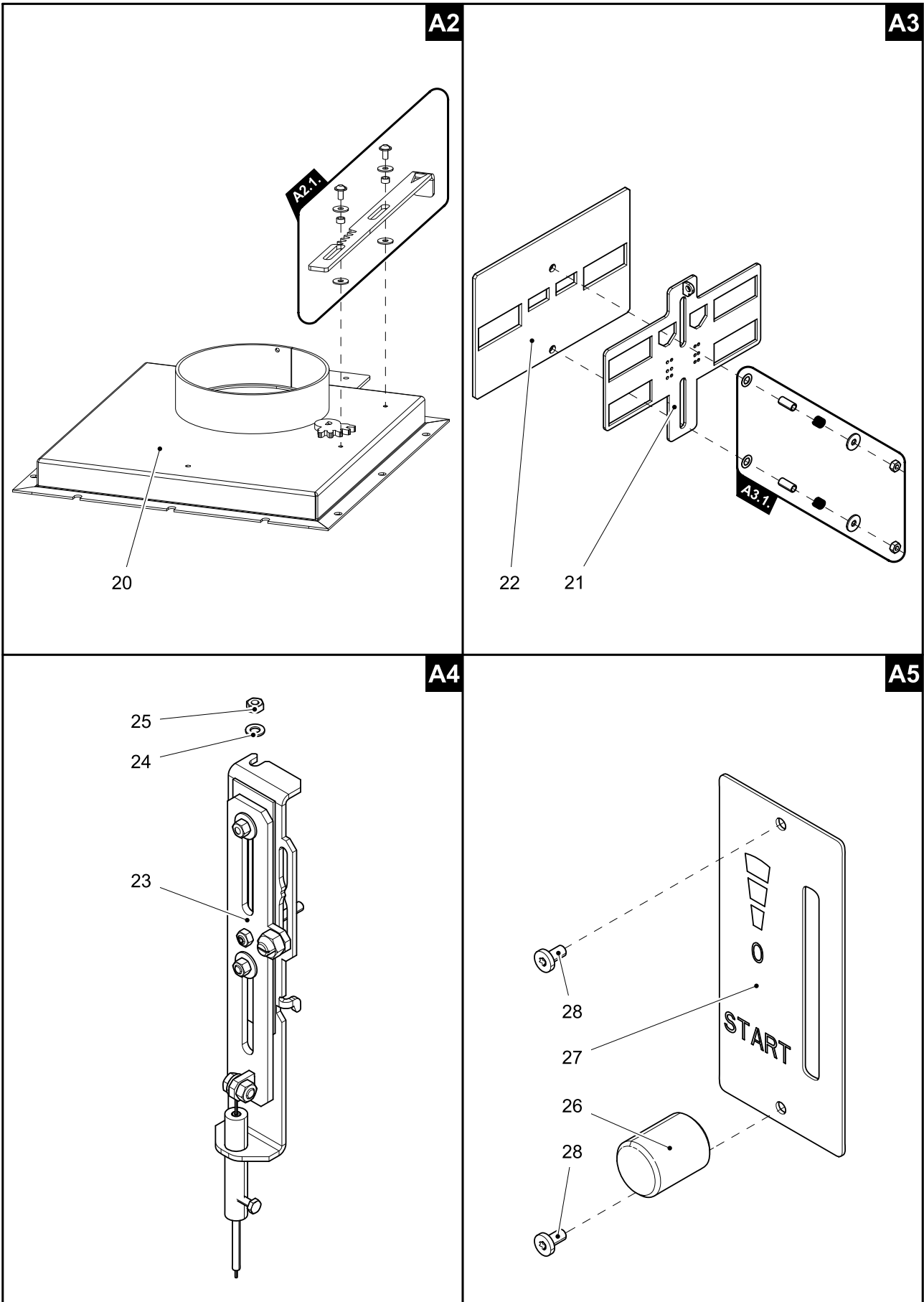

Detail A2			
Item	Name	Quantity	Number of goods
A2.1.	Flap drawbar/black — set	1 piece	0434515005088
20	Lid/black	1 piece	0434515015085
Detail A3			
Item	Name	Quantity	Number of goods
A3.1.	Sliding valve connecting material — set	1 piece	0434615005003
21	Sliding valve/black	1 piece	0434515005027
22	Sliding valve sealing	1 piece	0434515005052
Detail A4			
Item	Name	Quantity	Number of goods
23	Control/Easycontrol	1 piece	0434515005060
24	Washer 5,3 DIN 125A	1 piece	-
25	Nut M5 DIN 980V	1 piece	-
Detail A5			
Item	Name	Quantity	Number of goods
26	Controller	1 piece	0420915005625
27	Controller label	1 piece	0429415005171
28	Screw M3x10 BN 9524	2 piece	0030400300105

4. Dimensioned diagram

4.1. Knee-piece of exhaust of combustion products



Note

The knee-piece of exhaust of combustion products is delivered as optional accessory.

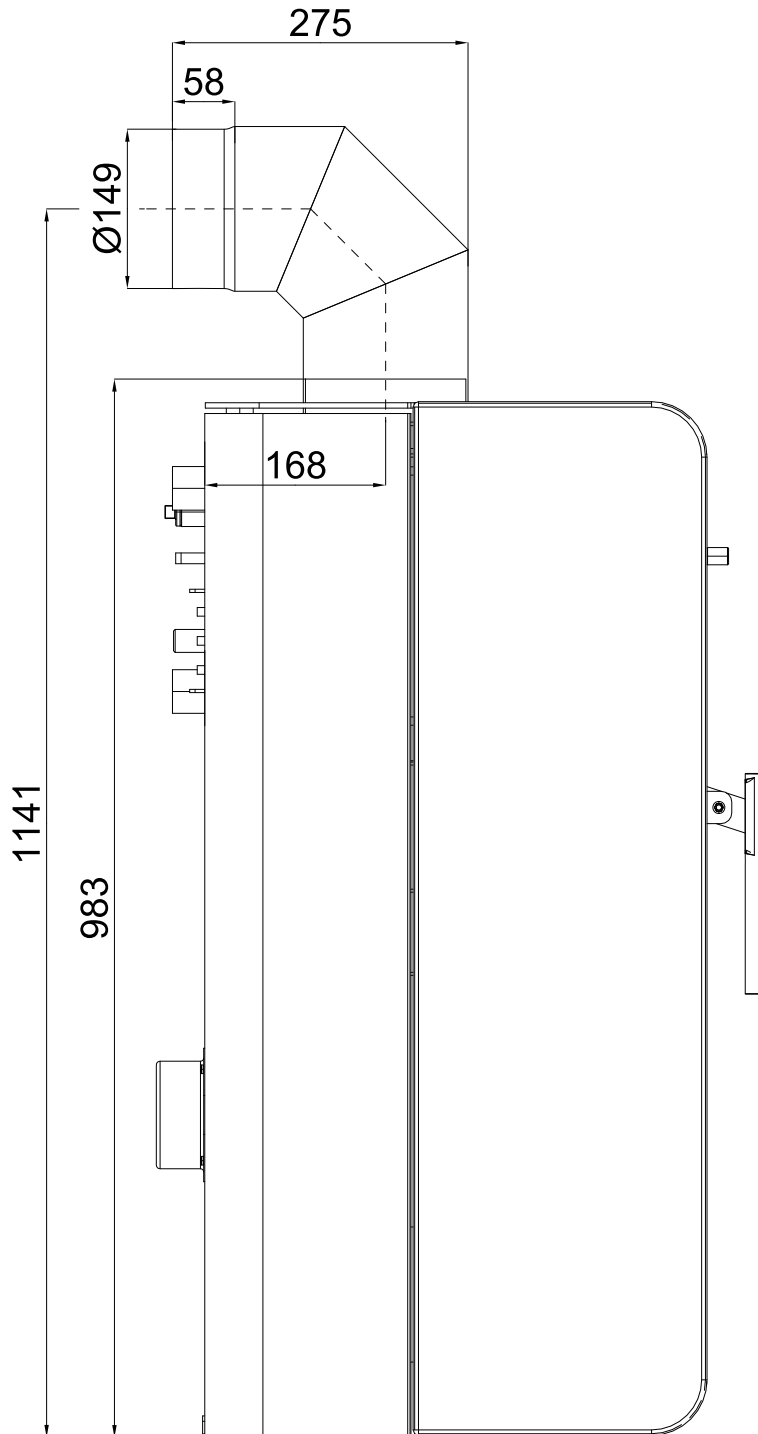

Dimensioned diagram

GB

4.2. Connection of the exchanger

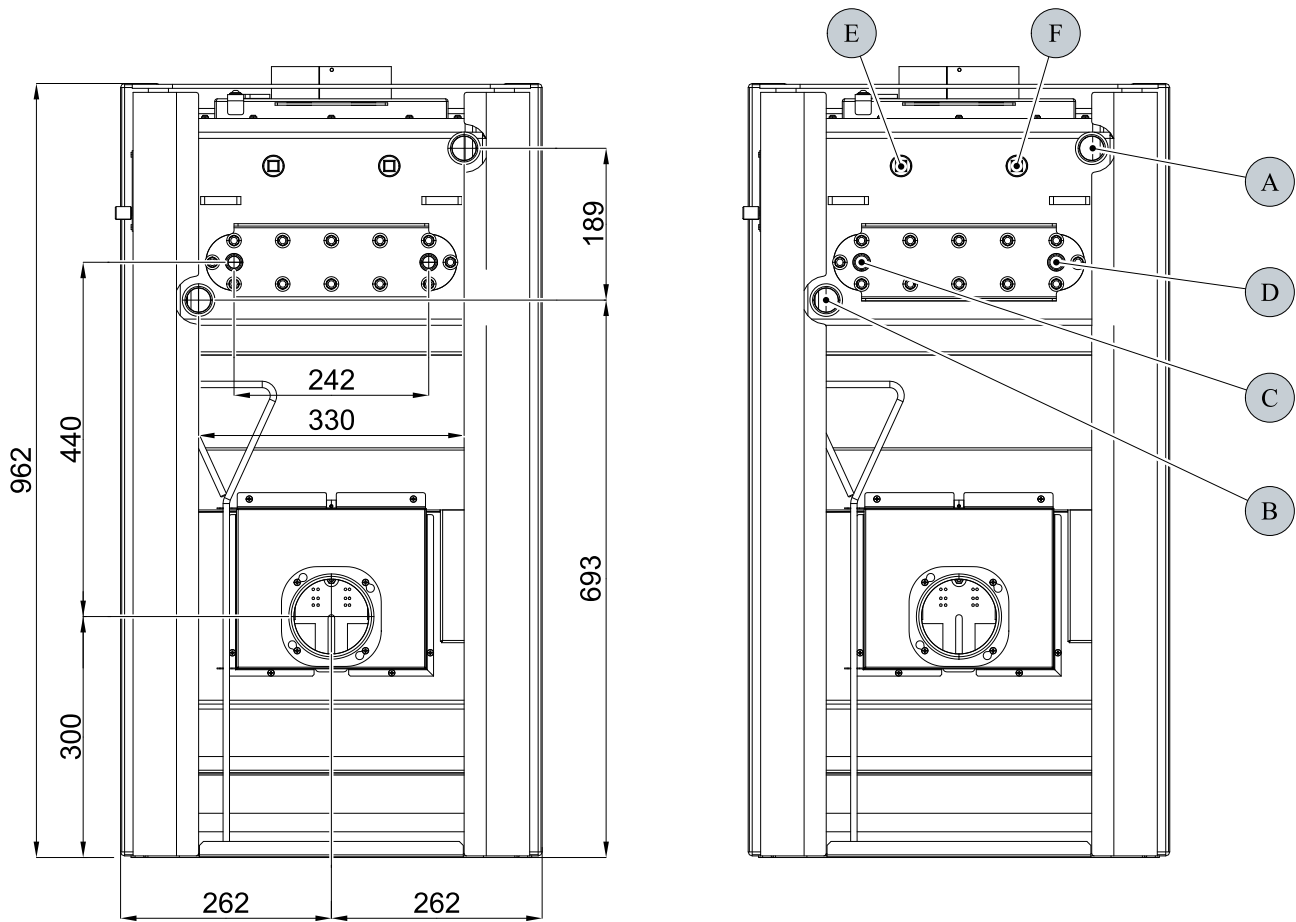

Item	Name
A	Forward flow connection (inside thread G1")
B	Reverse flow connection (inside thread G1")
C	Intake of cooling liquid (outside thread G1/2")
D	Outlet of cooling liquid (outside thread G1/2")
E	Hole for thermostatic sensor cup (inside thread G1/2")/cooling loop
F	Hole for thermostatic sensor cup (inside thread G1/2")/circulation pump

Dimensioned diagram

GB

5. Easy control

Control of all three air inputs - primary, secondary, tertiary - by means of one sole controller.

1. The controller is in the position intended for ignition (fig. A). All three air inputs are open (primary, secondary, tertiary).
2. The controller is in the position intended for burning of the stove after ignition (fig. B). Two air inputs are opened only (secondary, tertiary).
3. The controller is in the position designed to close air inputs (Fig. C). No input is open (primary, secondary, tertiary). This position is used only when the stove is out of operation, after finishing the heating process.



WARNING

Air inputs may not be closed during the heating operation (Fig. C)! In an extreme case, there can occur an explosion in the stove followed by breaking of glass, blowing up of cinders across the room and breaking out of the fire.

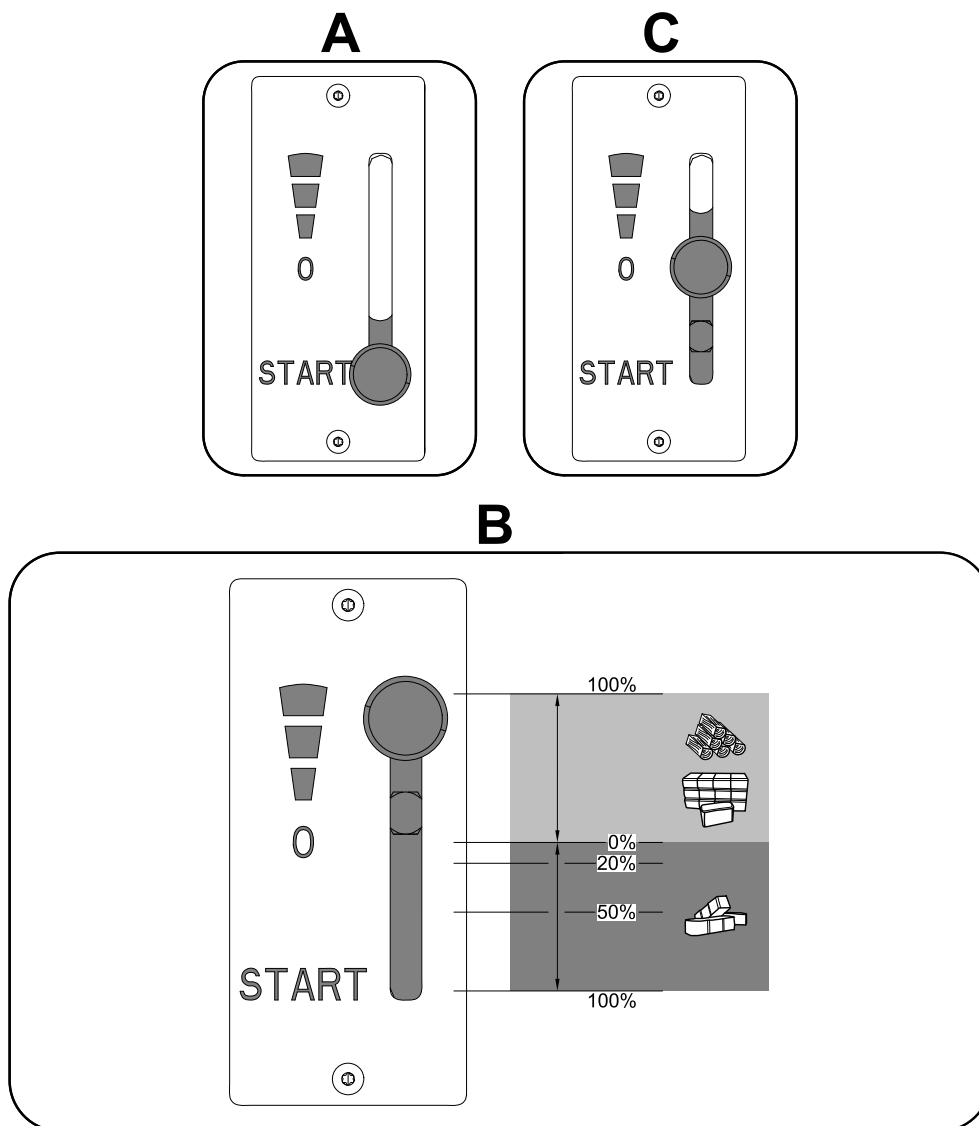

6. Installation of the coolant loop



IMPORTANT

Coolant loop not included in the scope of the delivery.

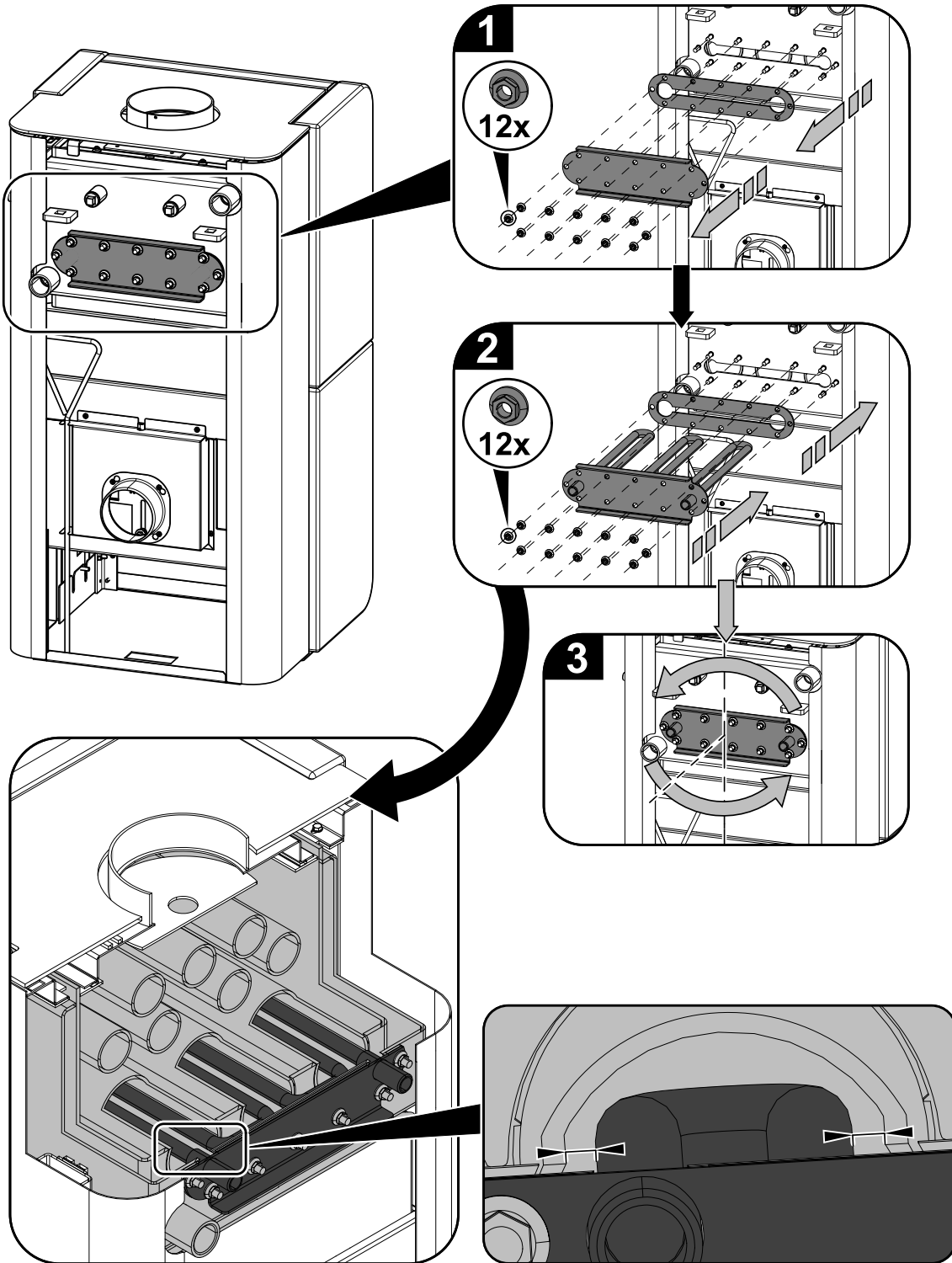

Installation of the coolant loop

GB

7. Instructions for cleaning of the exchanger



IMPORTANT

It is recommended to perform the cleaning by wiping blade (item 33, fig. 5) 1x in a week at least, or more often, depending on the manner of operation

1. Preparation and mounting of the cleaning drawbar.

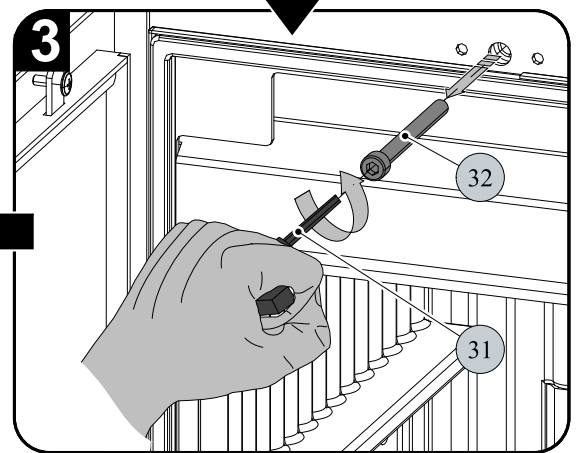
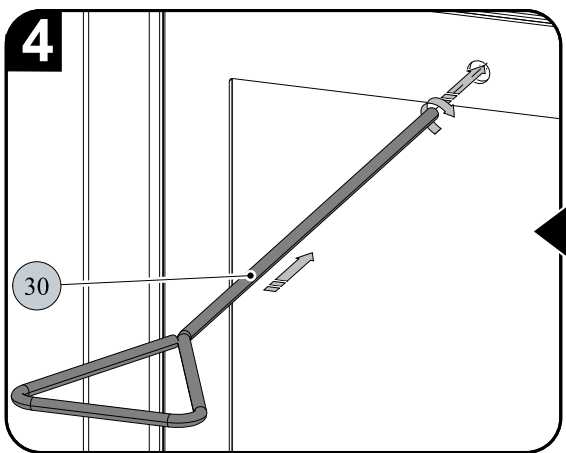
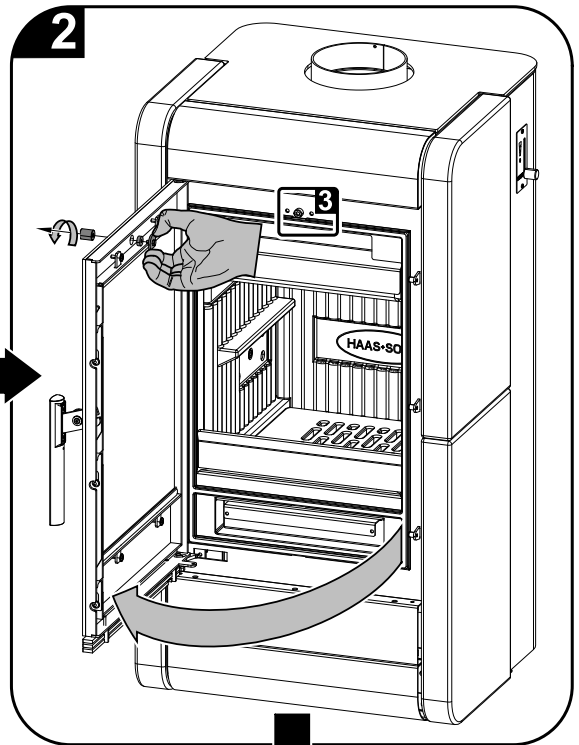
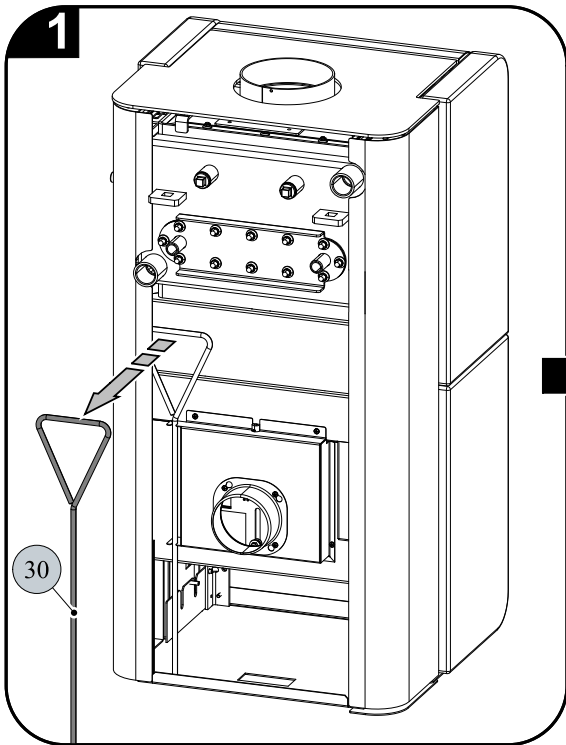

2. Proper cleaning and arrestment of the cleaning board.



IMPORTANT

Once the clearing is terminated, arrest the wiping blade always (fig. 5a). Do not leave the wiping blade above a flame (fig. 5b) and the orifice (a, fig. 6) passable freely.

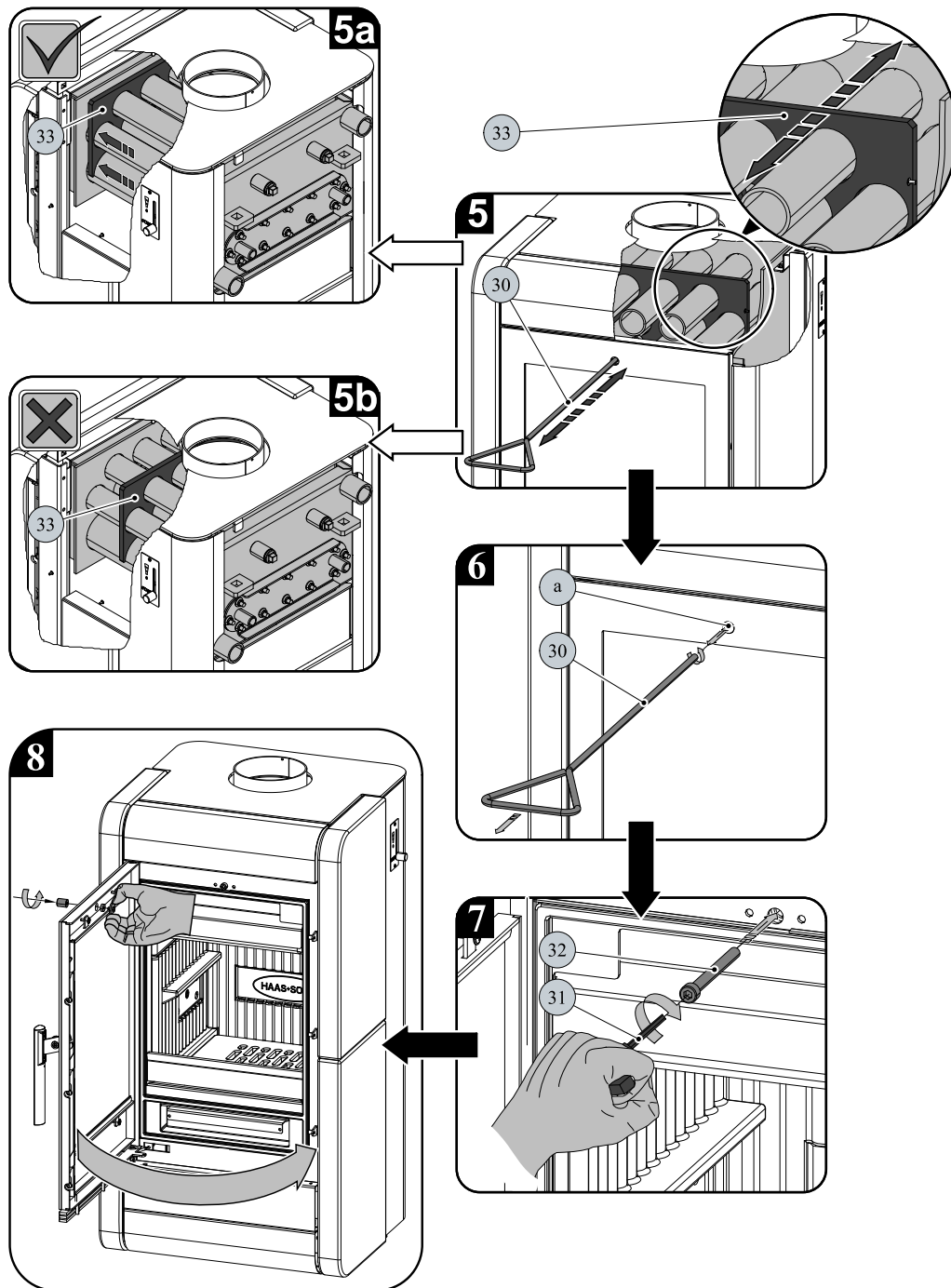

Item	Name	Number of the spare part
30	Drawbar of the cleaning/black	0433317005063
31	Allen wrench 8 mm (forms part of the delivery)	9001700080005
32	Screw M10x80 (DIN 912)	0030031000805
33	Wiping blade	—



