

HAAS
+
SOHN

Matera with exchanger

Equipment sheet
Fireplace stove with exchanger

GB

Introduction

We thank you very much for purchasing our product!

The description of the heating device will inform you in detail about the design, technical specification and operation of the heating device. We recommend you to acquaint yourselves closely with these data. In this way, you will avoid possible faults during the proper assembly and operation.

You will find detailed conditions of installation and operation in General Manual of Operation (included in the scope of the delivery).

Notes in the text

GB



Of utmost importance there are the notes entitled **WARNING**. The notes entitled **WARNING** advise you on **serious danger of damage to the heating device or of an injury**.



The note entitled **Notice** advises you on possible damage to your heating device.



The note entitled **Important** calls your attention to the information important for the operation of your heating device.



The note itself calls your attention to the information important for the operation of your heating device in general.

Contents

1. Technical data	1
2. Technical description	2
3. List of spare parts	3
3.1. Overall scheme of the model	3
3.2. Detail A1	5
4. Connection of the exchanger	6
4.1. Option without a cooling loop	6
4.2. Option with a cooling loop	7
5. Easy control	8
6. Kindling vent	9
7. Installation of the coolant loop	10
8. Instructions for cleaning of the exchanger	11
8.1. Long-time cleaning of the exchanger	11
8.2. Short-time cleaning of the exchanger	12

1. Technical data

Suitable fuel:

As concerns suitable fuel to be employed, see the chapter **2.2 Fuel** in the General Manual of Operation.

Proper operation:

As concerns the proper and safe operation of the fireplace stove, see the chapters **2. Description of the combustion process** and **5. Operating instructions** in the General Manual of Operation.

Instructions for the control of combustion process

Fuel		Output of the heating device	Quantity of fuel	Primary air	Secondary air	Tertiary air
Blockwood		100%	3,6 kg/hour (2 piece)	Easy control 100%		
		50%	1,7 kg/hour (1 piece)	Easy control 50%		

Length of wood logs: 33 cm (50 cm)

Technical data

	Blockwood
Nominal heat output	12,2 kW
Reduced heat output (50%)	—
Nominal power output for water heating	8,4 kW
Nominal power output delivered only by the body of the fireplace	3,8 kW
Maximum mass flow of dry combustion products	3,6 kg/hour
Average temperature of combustion products behind the smoke flue neck	282 °C
Maximum mass flow of dry combustion products	12,1 g/s
Energy efficiency	80,2 %
Average concentration of CO ₂	8,71 %
Concentration of CO in combustion products at 13% O ₂	1028 mg/Nm ³
Average concentration of dust at 13% O ₂	37 mg/Nm ³
The amount of combustion air at nominal output	35 m ³ /h
Tested in compliance with EN 13 240	

Technical information

Height	1100 mm
Width	963 mm
Depth	622 mm
Weight	313 kg
Diameter of the smoke flue	160 mm
Maximum operating over-pressure of the exchanger	0,2 MPa
Water contents of the exchanger	15 l
Recommended heat gradient (t _{output} – t _{input})	75 – 60 °C
Min. chimney stack draught in the smoke flue neck	12 Pa
Heating capacity (middle heat losses) at 12,2 kW	cca 220 m ³
Controllable output	4 – 12,2 kW

2. Technical description

Technical description

GB

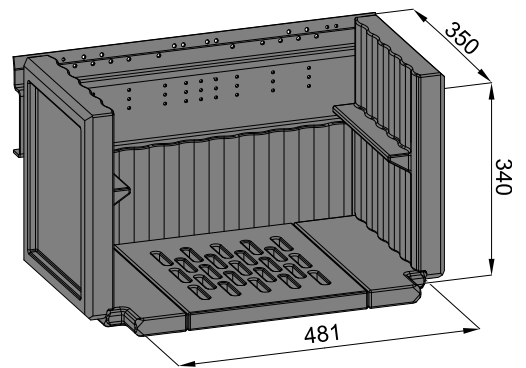
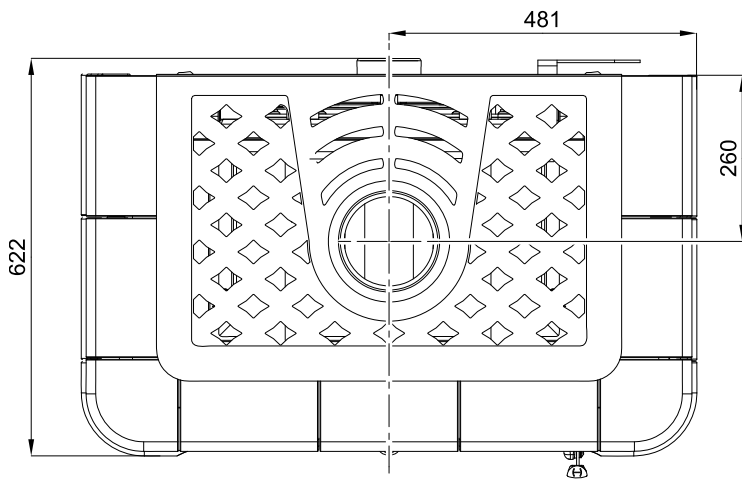
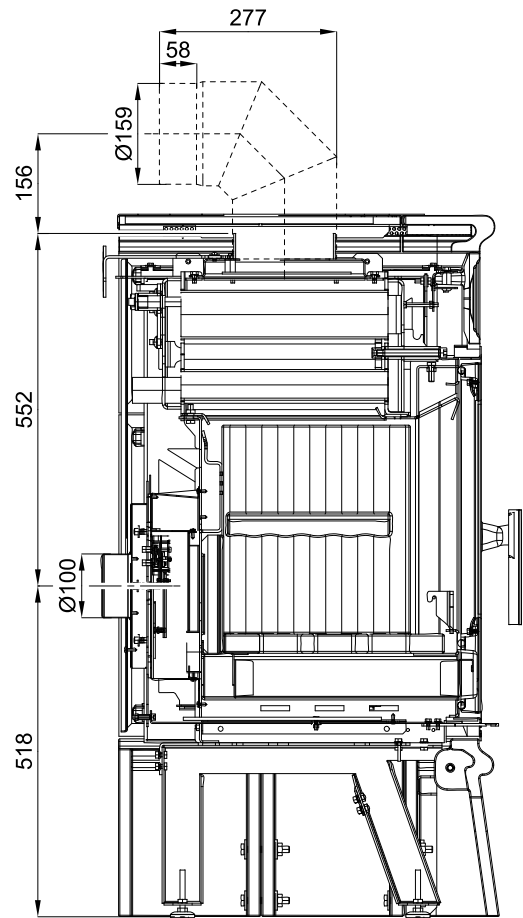
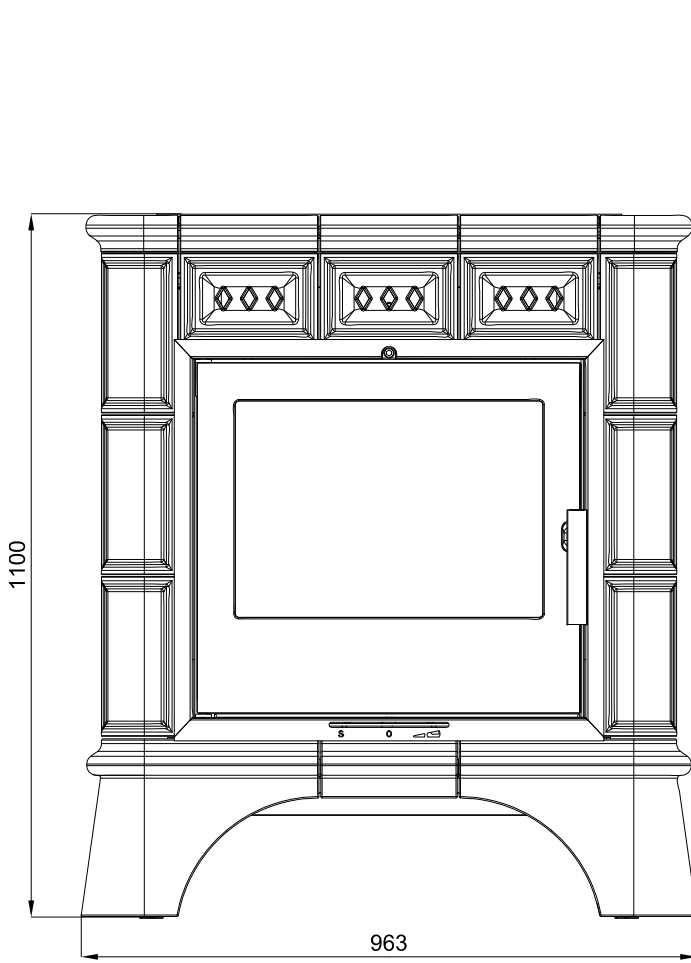

3. List of spare parts

3.1. Overall scheme of the model

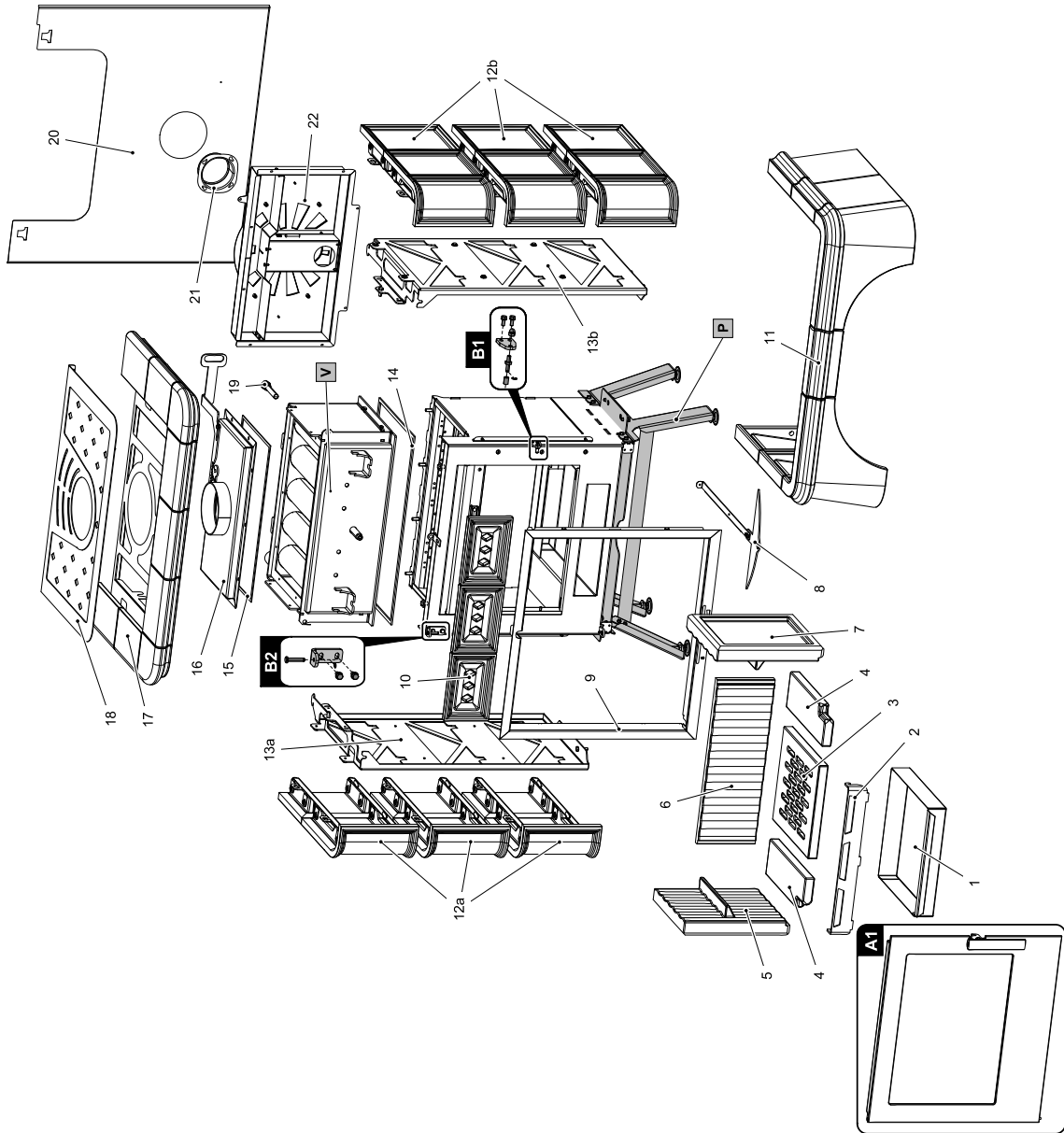

Overall scheme of the model			
Item	Name	Quantity	Number of goods
A1	Cast iron furnace door (complete)/black	1 piece	0619018155300
B1	Door lock (complete)	1 piece	0619018165007
B2	Strip connecting material (complete)	1 piece	0619018155005
1	Ashpan	1 piece	0432317005600
2	Protection/black	1 piece	0419018155006
3	Fire grate made of heat resistance concrete	1 piece	0619018155552
4	Refractory lining – bottom (30x114x345)	2 piece	0619018155554
5	Refractory lining – left (85x295x342)	1 piece	0619018155551
6	Refractory lining – rear (35x185x530)	1 piece	0619018155553
7	Refractory lining – right (85x295x342)	1 piece	0619018155511
8	Control drawbar/black	1 piece	0435215005011
9	Frame/black	1 piece	0435215005400
10	Ceramic front tiles/honey cake	1 piece	0435215005120
10	Ceramic front tiles/ivory	1 piece	0435215015120
11	Ceramic base/honey cake	1 piece	0435215005150
11	Ceramic base/ivory	1 piece	0435215015150
12a	Ceramic lateral lining — left/honey cake	3 piece	0435215005113
12a	Ceramic lateral lining — left/ivory	3 piece	0435215015113
12b	Ceramic lateral lining — right/honey cake	3 piece	0435215005133
12b	Ceramic lateral lining — right/ivory	3 piece	0435215015133
13a	Holder — left/black	1 piece	0435215005110
13b	Holder — right/black	1 piece	0435215005130
14	Sealing cord of the exchanger 10x4 mm	1520 mm	0040210040005
15	Sealing cord of the exchanger cover 10x4 mm	1850 mm	0040210040005
16	Exchanger cover/black	1 piece	0435215005002
17	Ceramic mantelpiece/honey cake	1 piece	0435215005140
17	Ceramic mantelpiece/ivory	1 piece	0435215015140
18	Top cover	1 piece	0435215005160
19	Rear cover	1 piece	0435215005007
20	Sensor holder	1 piece	0431317006050
21	External air input (Ø100)	1 piece	0088500050008
22	Air module	1 piece	0419018155500

P	Base/black	1 piece	0435215005500
V	Exchanger/black	1 piece	0419018205050

3.2. Detail A1

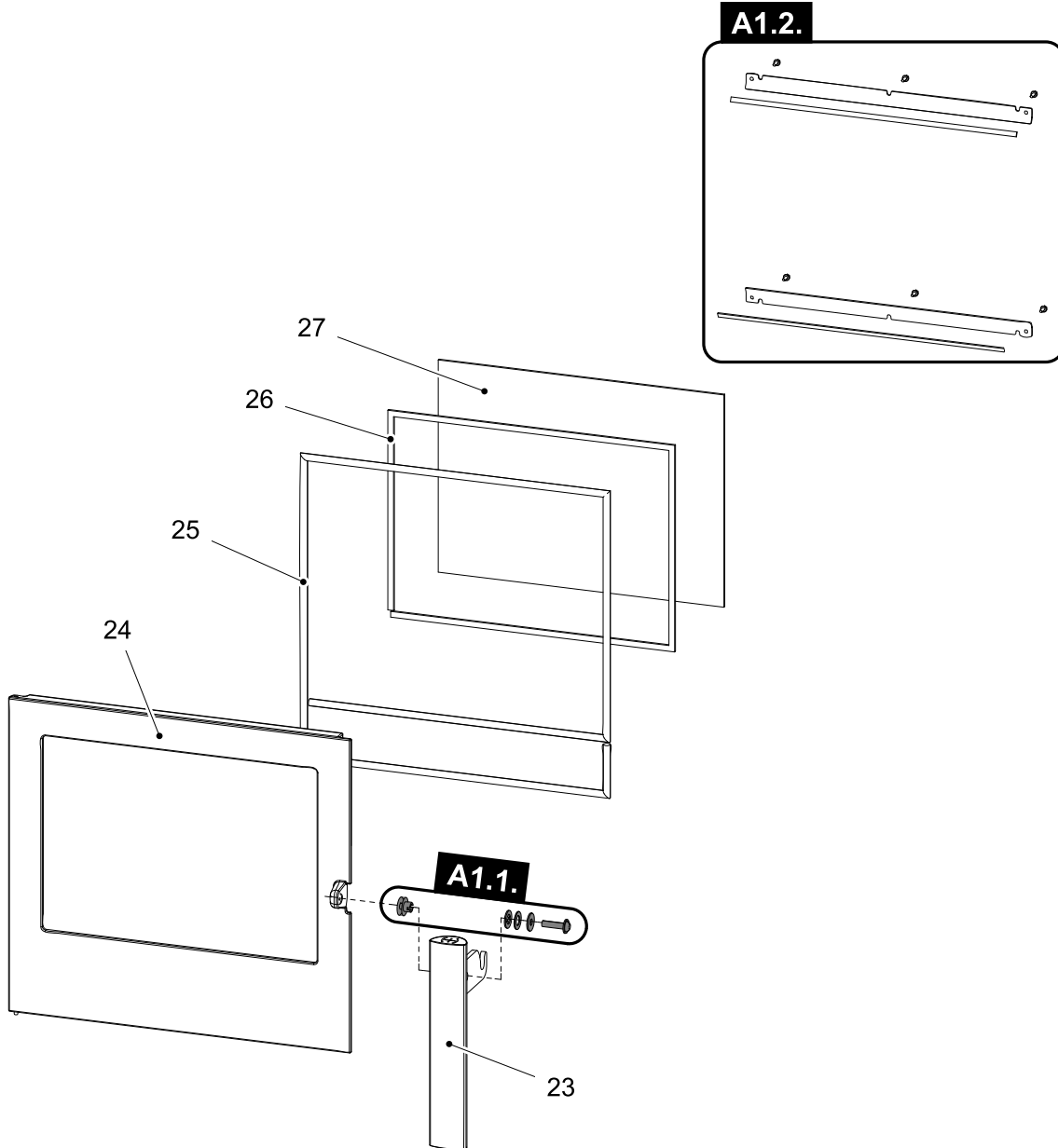

Detail A1			
Item	Name	Quantity	Number of goods
A1.1. + 23	Fire-box door lever lock (complete) + handle connecting material – set	1 piece	0420114017301
A1.2.	Glass holder – set/black	1 piece	0619018155303
24	Cast iron furnace door/black	1 piece	0619018155301
25	Door sealing cord 10 mm	2600 mm	0040300100005
26	Glass sealing cord 10x4 mm	1700 mm	0040210040005
27	Refractory glass (4x370x501)	1 piece	0619018155302

4. Connection of the exchanger

4.1. Option without a cooling loop

Connection of the exchanger

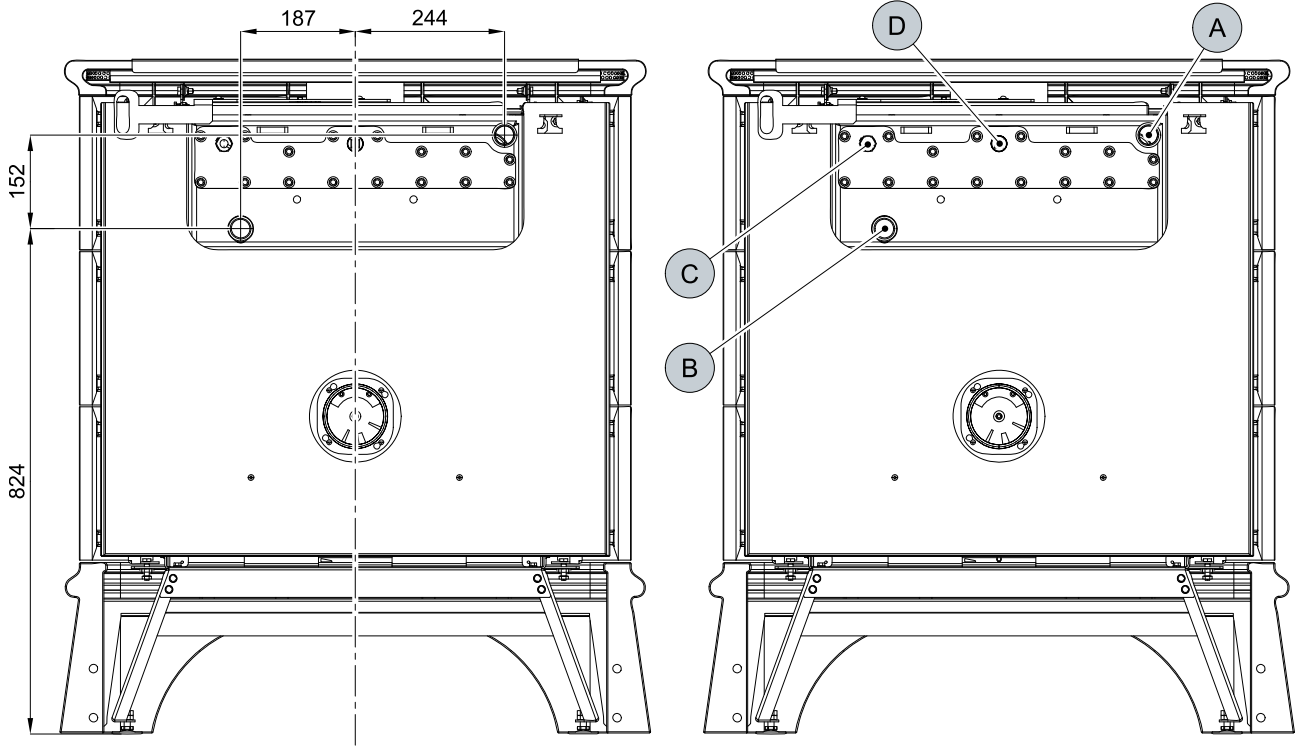

Item	Name
A	Outlet of heating water (inside thread G1")
B	Intake of return water (inside thread G1")
C	Opening with a thermostatic sensor holder (inside thread G1/2")/circulation pump
D	Hole for thermostatic sensor cup (inside thread G1/2")/cooling loop

GB

4.2. Option with a cooling loop

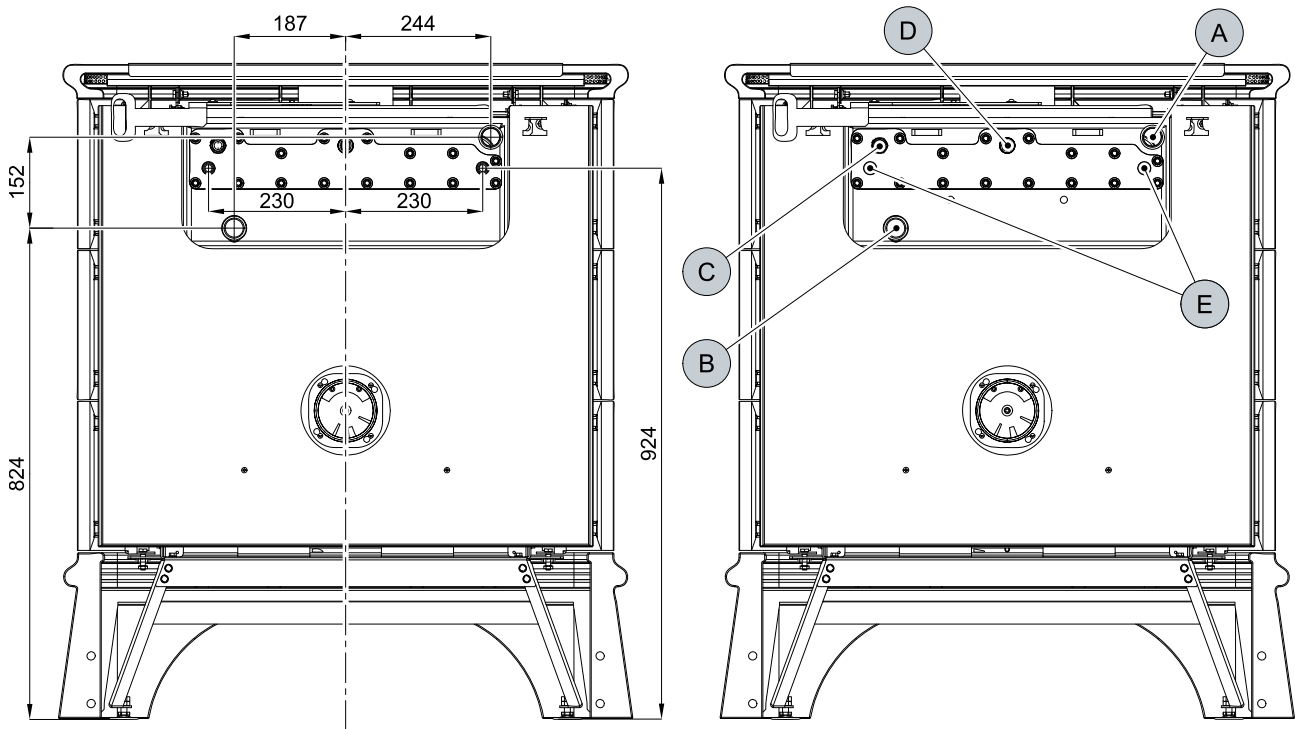

Item	Name
A	Outlet of heating water (inside thread G1")
B	Intake of return water (inside thread G1")
C	Opening with a thermostatic sensor holder (inside thread G1/2")/circulation pump
D	Hole for thermostatic sensor cup (inside thread G1/2")/cooling loop
E	Cooling loop inputs/outputs (outside thread G1/2")

5. Easy control

Control of all three air inputs (primary, secondary, tertiary) by means of one sole controller.

1. The controller is in the position intended for ignition (fig. A). All three air inputs are open (primary, secondary, tertiary).
2. The controller is in the position intended for burning of the stove after ignition (fig. B).
3. The controller is in the position designed to close air inputs (Fig. C). No input is open (primary, secondary, tertiary). This position is used only when the stove is out of operation, after finishing the heating process.



WARNING

Air inputs may not be closed during the heating operation (Fig. C)! In an extreme case, there can occur an explosion in the stove followed by breaking of glass, blowing up of cinders across the room and breaking out of the fire.

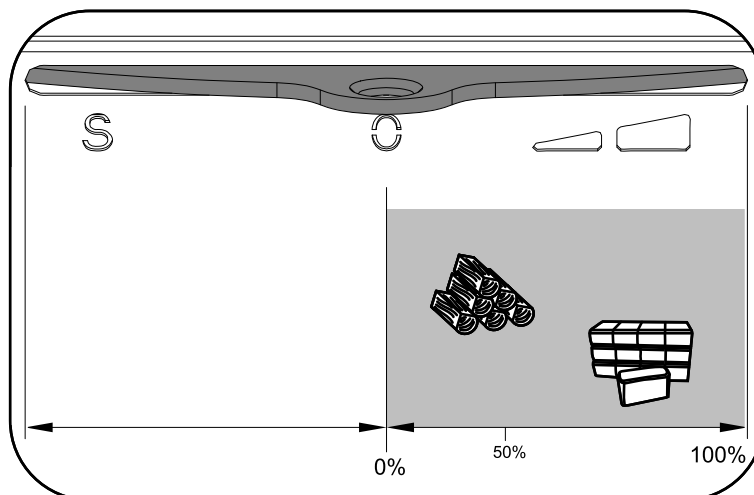
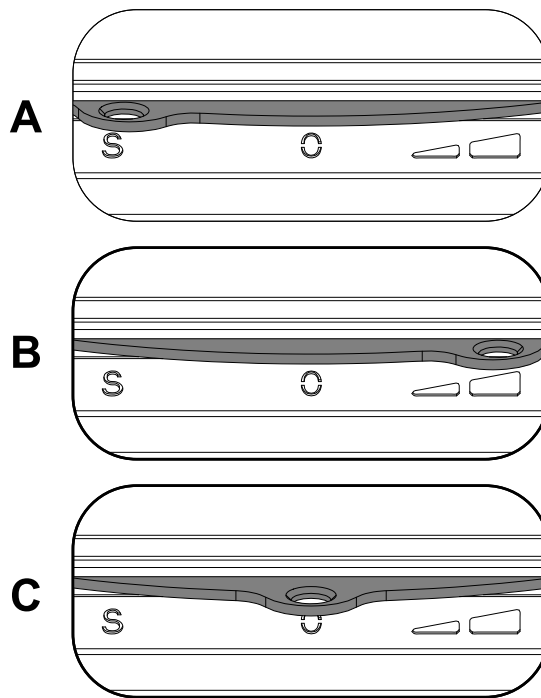

6. Kindling vent



IMPORTANT

When lighting the stove or if the stove has a weak draft, push the ignition flap controller to Position 1 (Fig. A). In this position, the ignition flap is open. During the heating, pull out the ignition flap controller to Position 0 (Fig. B). In this position, the ignition flap is closed.



Note

Keep in mind that heating efficiency is significantly reduced, the fuel consumption increases and emission parameters deteriorate when heating with the kindling vent open for a prolonged period of time!

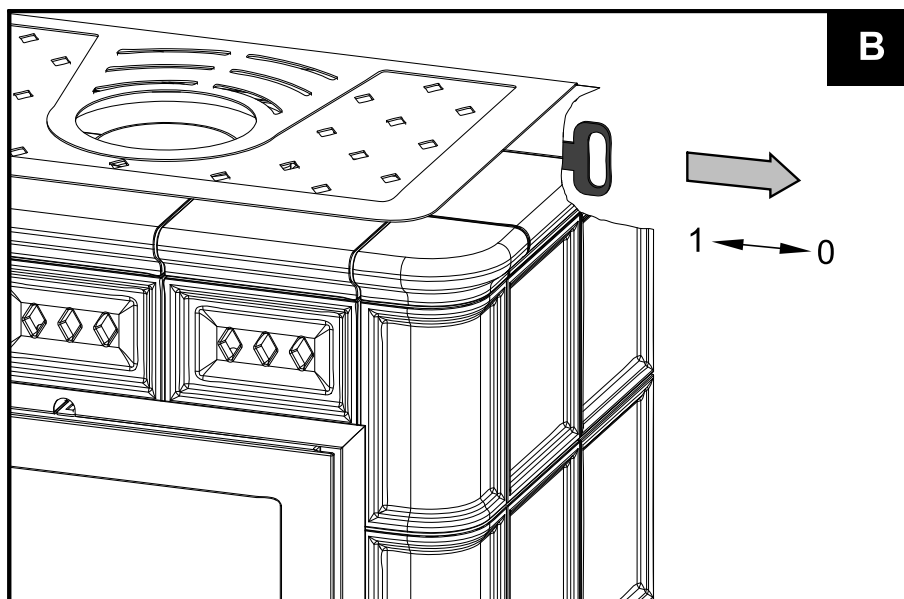
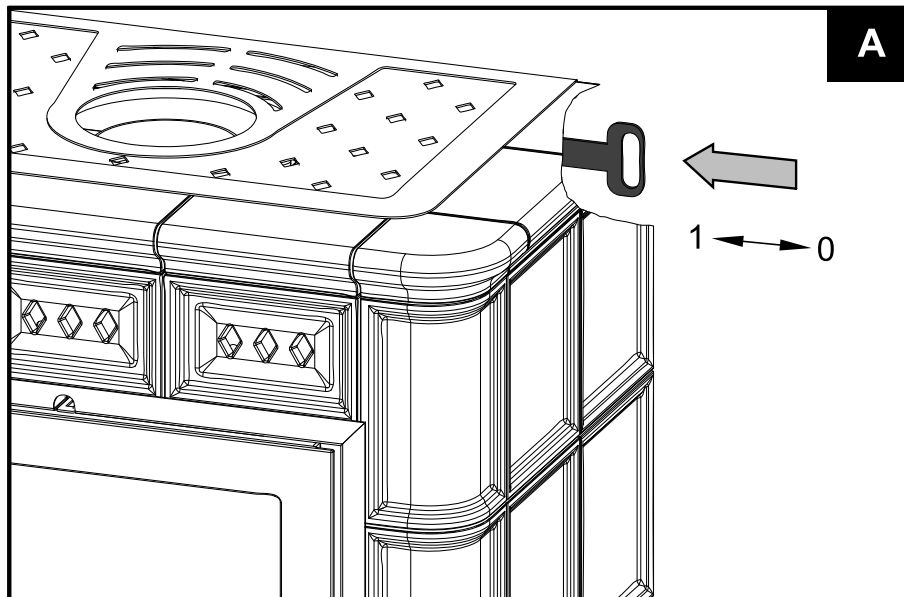

7. Installation of the coolant loop



IMPORTANT

The cooling loop is supplied as a special accessory.

Installation of the coolant loop

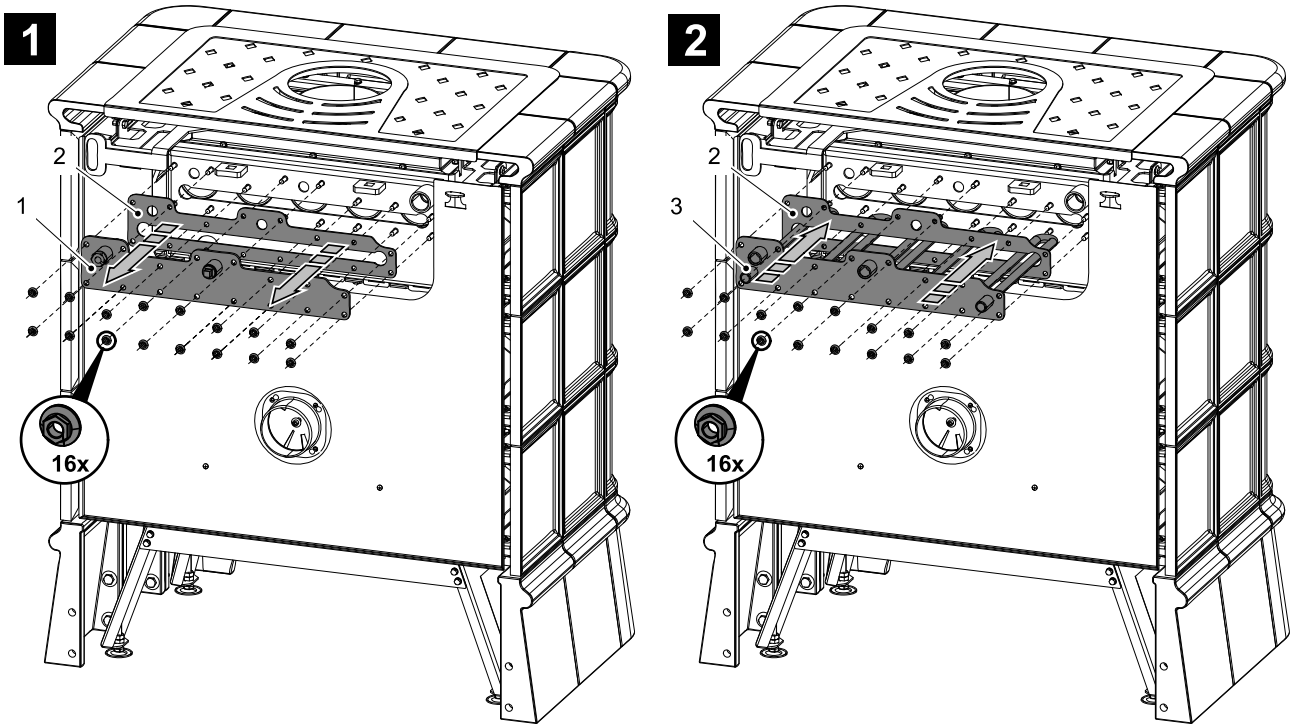

Item	Name	Number of goods
1	Loop cover/black	0419018305023
2	Sealing	0419018305013
3	Coolant loop	0419018155018

GB

8. Instructions for cleaning of the exchanger

8.1. Long-time cleaning of the exchanger



CAUTION

Cleaning of the exchanger should be done from above after removal of the exchanger cover or from the bottom of the furnace, at least once a year (e.g. before the heating season).

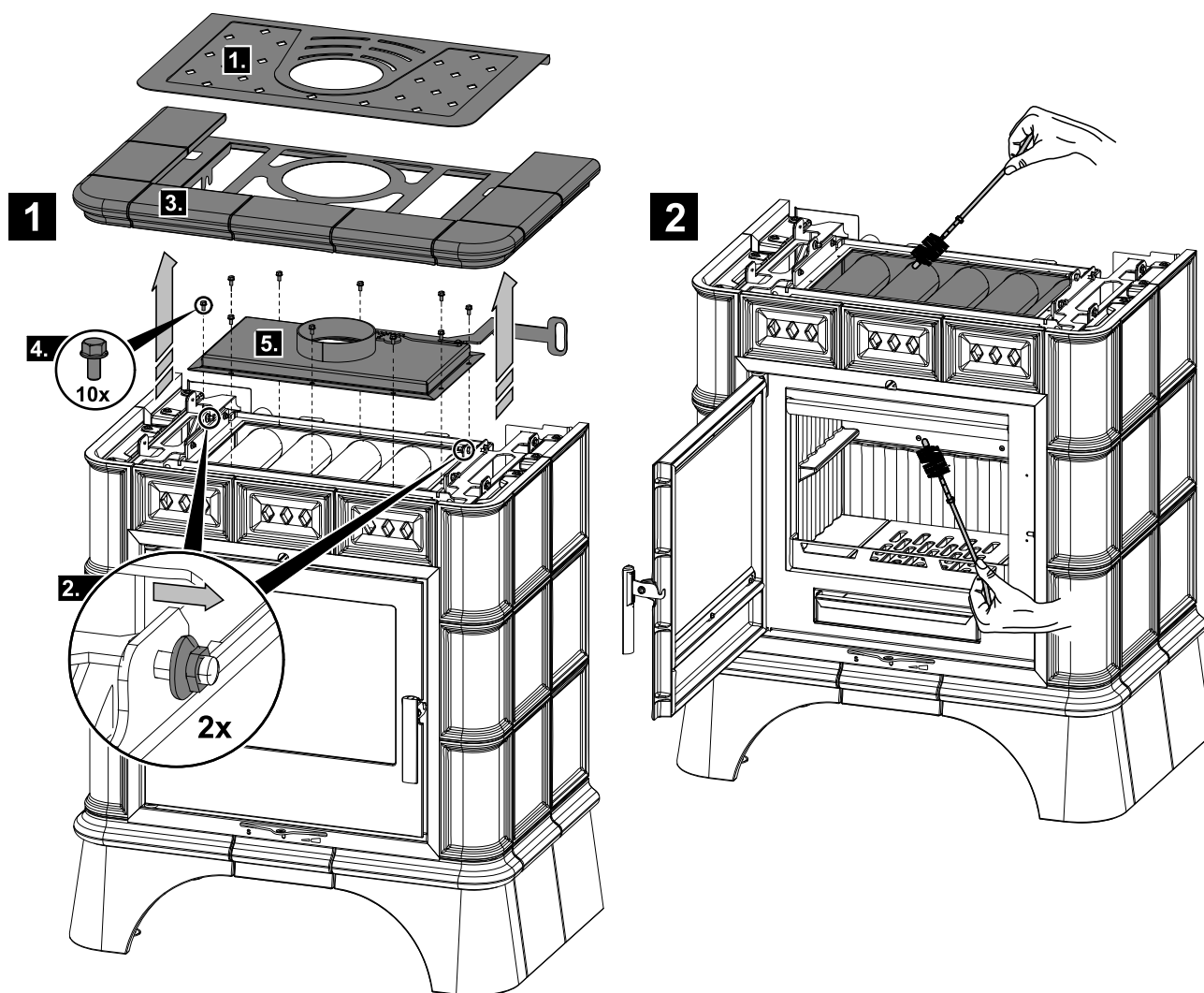

8.2. Short-time cleaning of the exchanger



IMPORTANT

It is recommended to clean the surfaces with the wiper blades (Item 4, Fig. 3) at least once a week, or even more frequently depending on how often the furnace is used.

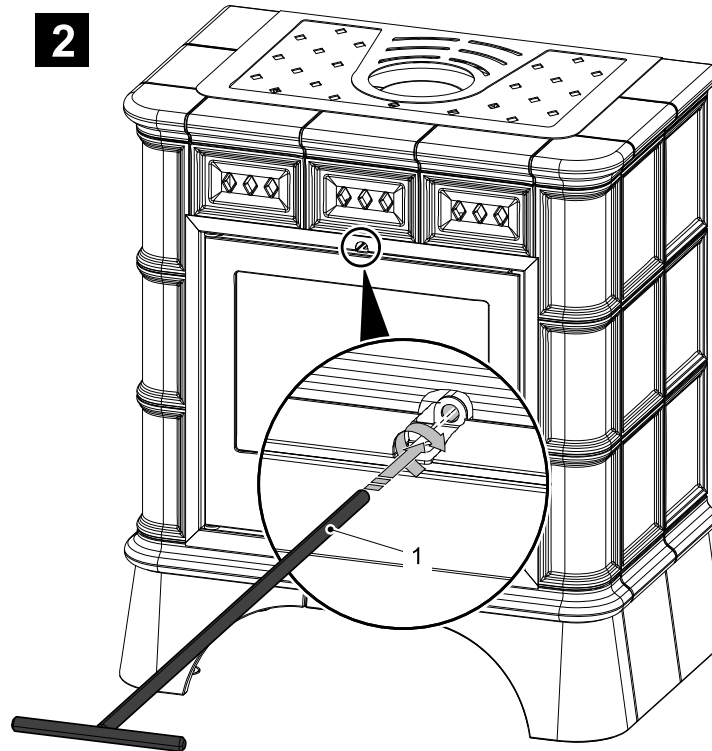
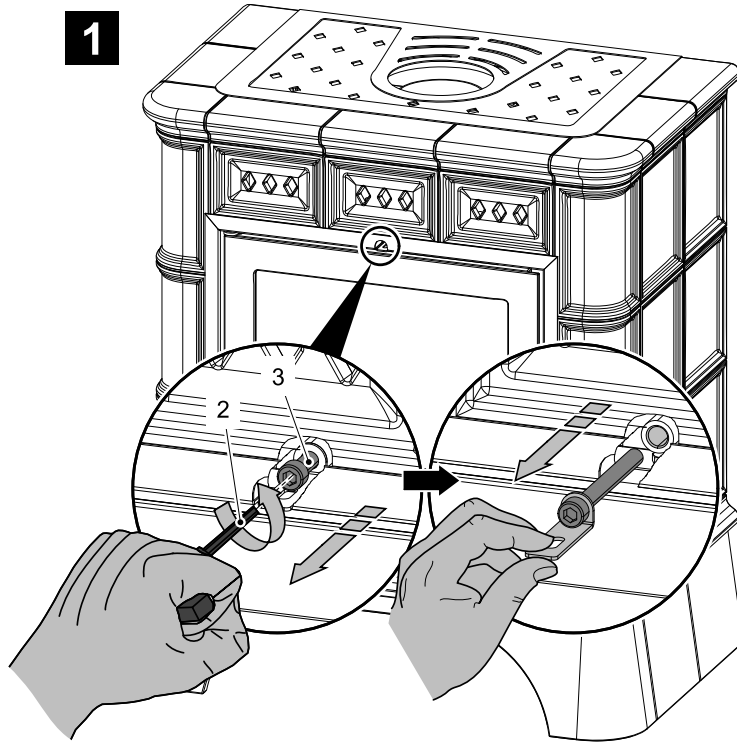

3

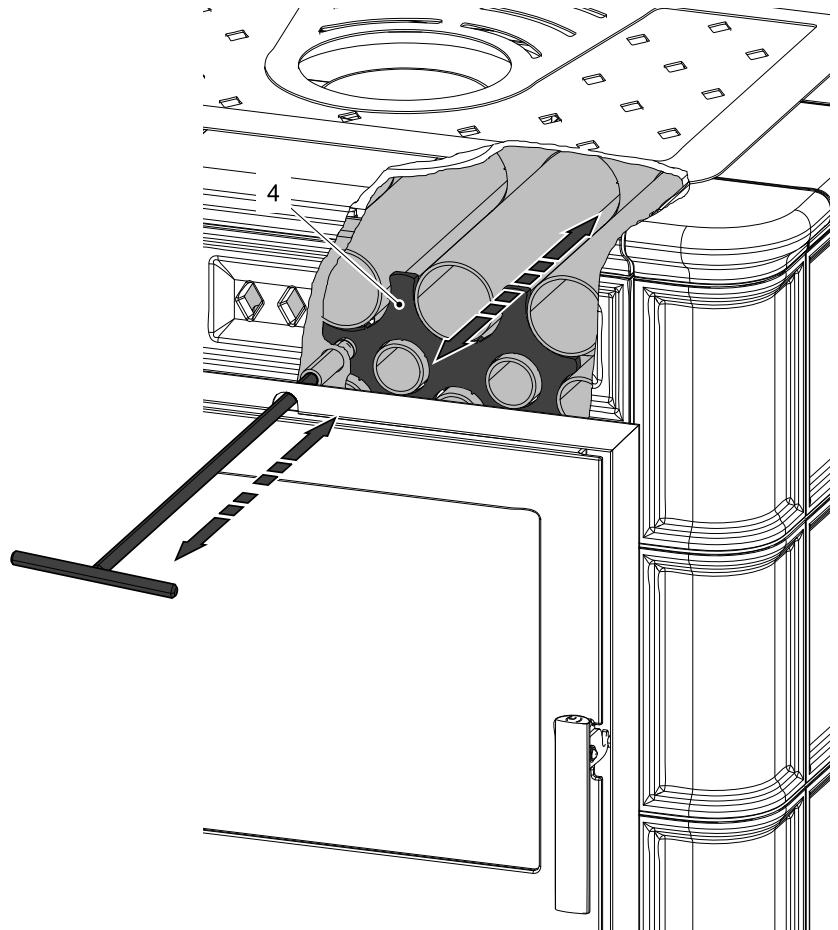
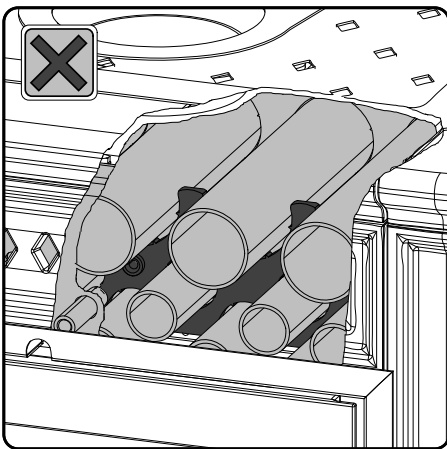
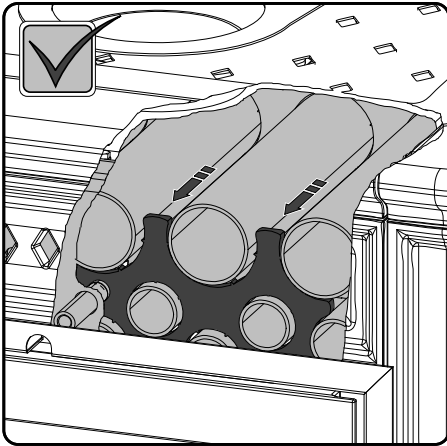

Item	Name	Number of goods
1	Drawbar of the cleaning/black	0433317005063
2	Allen wrench 8 mm (forms part of the delivery)	9001700085002
3	Screw M10x70 (DIN 912)	0030031001005
4	Wiping blade	-



